



Technical Manual for Hubs

Table of Contents

StudioHub+ Master Pin Out Chart	4
HUB16-DC & HUB8-DC	5
16 & 8 Channel Break-Out Hubs with DC-Link	
HUB18-DC	6
18 Channel Break-Out Hub with DC-Link	
HUB32	7
32 Channel Break-Out Hub	
HUB36-DC	8
36 Channel Break-Out Hub with DC-Link	
HUB12	9
12 Channel Audio Card Break-Out Hub (rack mount)	
HUB24	10
24 Channel Thru-put Hub (rack mount)	
HUBRIO	11
32 Channel Break out Hub for SAS RIO Studio Engine (rack mount)	
GPI12/24	12
12/24 Channel GPI Relay Hub (rack mount)	
GPI16	12
16 Channel GPI Relay Hub (rack mount)	
MiniTie12-4	13
4 wire / 12 channel Tie-Line Hub (mini wall mount)	
MiniTie24-4	13
4 wire / 24 channel Tie-Line Hub (mini wall mount)	
MiniTie6-8	14
8 wire / 6 channel Tie-Line Hub (mini wall mount)	
MiniTie12-8	14
8 wire / 12 channel Tie-Line Hub (mini wall mount)	
Tie12-4DC	15
4 wire / 12 channel Tie-Line Hub with DC-Link	
Tie24-4DC	15
4 wire / 24 channel Tie-Line Hub with DC-Link	
Tie12-8	16
8 wire / 12 channel Tie-Line Hub	
Tie24-8	17
8 wire / 24 channel Tie-Line Hub	
Patch44	17
44 Channel Patch Panel	
Patch48	19
48 Channel Patch Panel	
Sum8, Sum4	21
Active Summing Amp Hubs	
DA12-DC, DA6-DC	22
Active Distribution Amp Hubs with DC-Link	

StudioHub+ Master Pin Out Chart

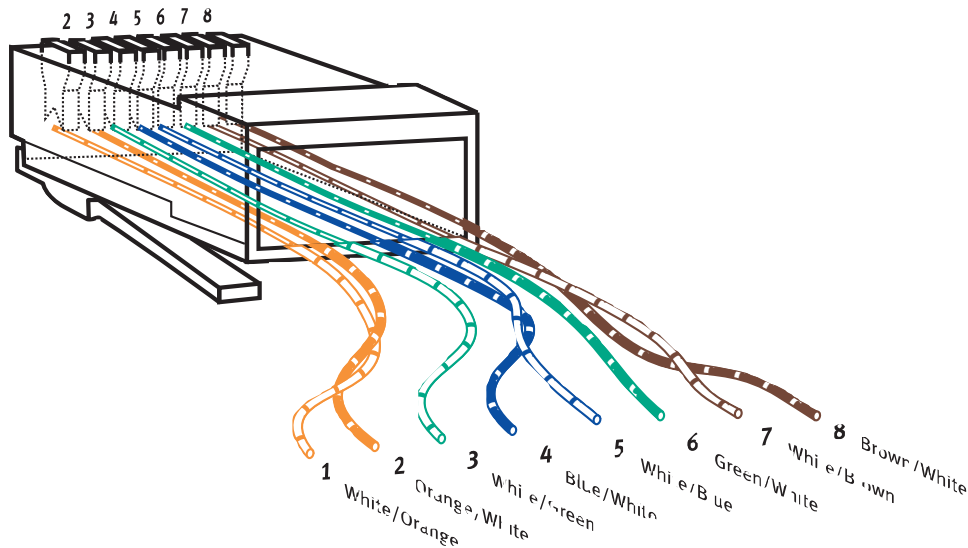

StudioHub+ RJ-45 Pinout

Channel	Color Pair	RJ-45 Pins	110 Pins	Ethernet
L+ / AES+	Wht/Org	1	3	TR+
L- / AES-	Org/Wht	2	4	TR-
R+	Wht/Grn	3	5	R+
R-	Grn/Wht	6	6	R-
nc	Wht/Blu	5	1	n/c
GND	Blu/Wht	4	2	n/c
15V-	Wht/Brn	7	7	n/c
15V+	Brn/Wht	8	8	n/c
Shield	Wht/Sl't	Shield	9	X
Shield	Sl't/Wht	Shield	10	X

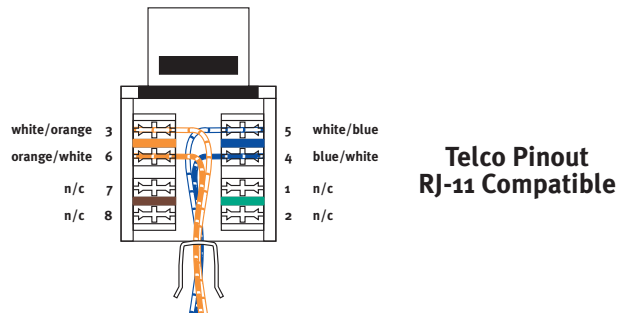
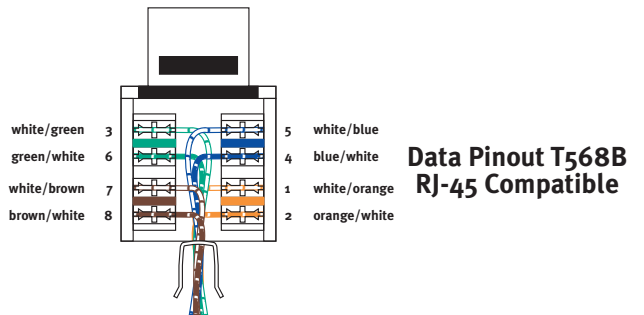

StudioHub+ RJ-21 25 Pair Pinout

Pair	Color	RJ-21 Pins	RJ-45 #
1/2	wht,blu/wht,org	26,1/27,2	1
3/4	wht,grn/wht,brn	28,3/29,4	2
5/6	wht,slt/red,blu	30,5/31,6	3
7/8	red,org/red,grn	32,7/33,8	4
9/10	red,brn/red,slt	34,9/35,10	5
11/12	blk,blu/blk,org	36,11/37,12	6
13/14	blk,grn/blk,brn	38,13/39,14	7
15/16	blk,slt/yel,blu	40,15/41,16	8
17/18	yel,org/yel,grn	42,17/43,18	9
19/20	yel,brn/yel,slt	44,19/45,20	10
21/22	vio,blu/vio,org	46,21/47,22	11
23/24	vio,grn/vio,brn	48,23/49,24	12
25	vio,slt	50,25	Ground

For Assys:
HUB16-DC
HUB8-DC
Rev: 01/05

StudioHub+ Model HUB16-DC and HUB8-DC

Engineered for StudioHub+ and High-Speed Ethernet Connectivity

Model HUB16 pictured

Also available as Ω hub 8 channel - model Hub8

Product Key	
Name	HUB16 / HUB8
Mount	Hub (3 r.u.)
Channels	16 / 8
CAT-5 Pairs	4 (all)
Power Link	yes
Connectors	2 RJ-45 & 110
Versions	Full Hub/Half Hub/Board Only

General

Each of 16 (or 8 if ordered in the Ω Hub model) Hub channels consists of an RJ-45 input connector in parallel with an output RJ-45 connector and a 110-style punch connector. Each channel carries a stereo balanced audio pair, or balanced digital audio signal, and an optional +/- 15 DC voltage. Equipment cabling may also be "punched down" to the inline 110 connector.

DC Power

If using any StudioHub+ "DC-Link" accessories, plug a StudioHub +/- 15 volt power supply into the power supply connector. Both Hub LEDs will illuminate. Insert both power jumpers and the DC ground jumper on only the circuits that utilize a powered accessory (e.g. MatchJack, mic preamp, etc.).

Grounding Information

Cable and connector shields are contiguous from each individual hub channel (input to output) but are normally isolated from other channels.

To use the hub as a common ground point, insert the jumper below each left-hand RJ-45 that you want common to the chassis ground. If you have a StudioHub+ 15V power supply connected to the hub, and JU-33 is jumpered, chassis ground, electrical ground, and shield are common.

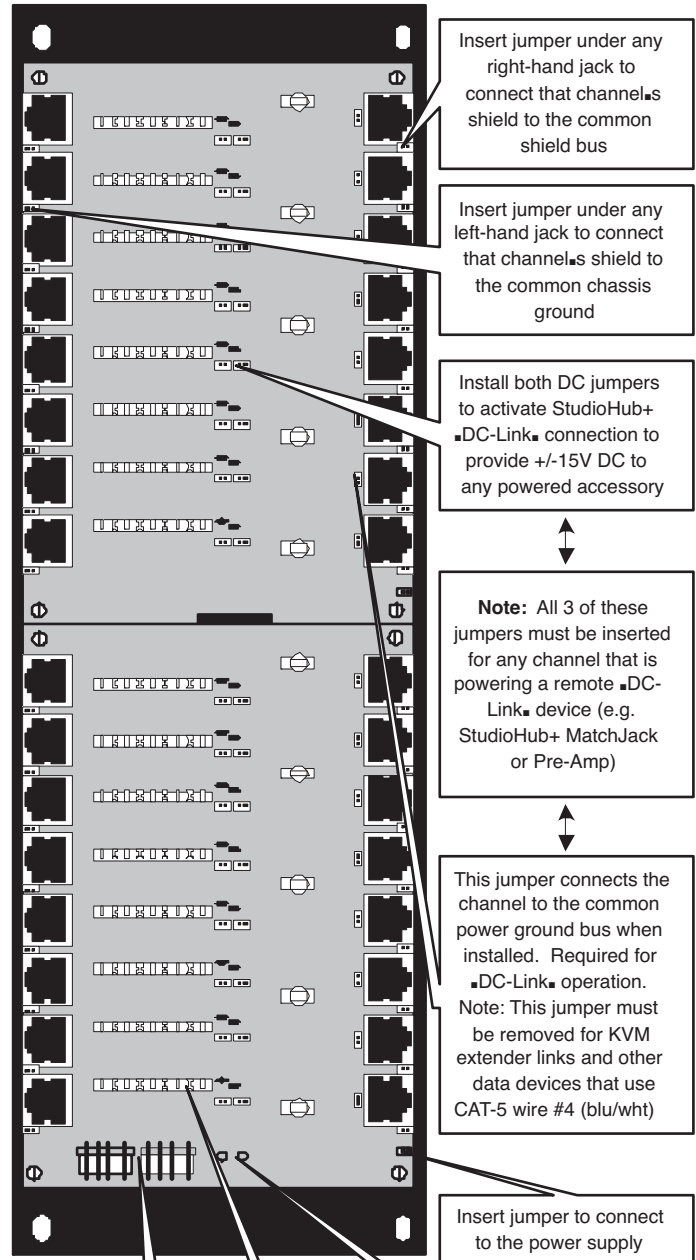
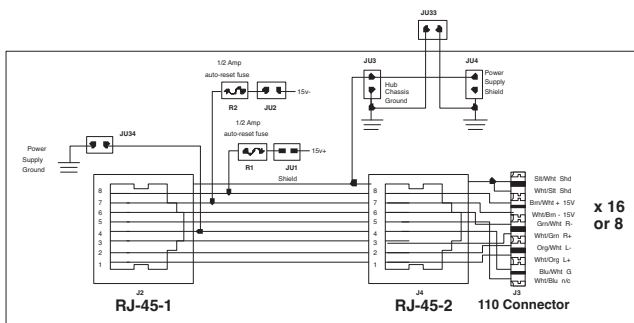

LEDs indicate presence of +/- 15V DC

+/-15V external power supply main and loop-thru jumpers

10 pin 110-style connector provides access to all 4 CAT-5 pairs and cable shield

For Assy:
HUB18
Rev: 05/08/13

StudioHub+ Model HUB18-DC

Engineered for Break-Out Harnesses

Product Key	
Name	HUB18
Mount	Hub (3 R.U)
Channels	18
CAT-5 Pairs	2 (pins - 1,2,3&6)
Power Link	yes
Connectors	Mini-amp & RJ-45
Versions	Full Hub

General

Each of 18 Hub channels consists of two 2-pin mini-Amp input connector in parallel with an RJ-45 connector and 100-style punch-down connector. Each channel carries a stereo balanced audio pair, or balanced digital audio signal. Custom length and configuration harness cables must be factory ordered to interconnect the Hub to various consoles, audio routers and engines or multi-channel Digital Audio Workstations.

DC Power

If using any StudioHub+ "DC-Link" accessories, plug a StudioHub+ +/- 15 volt power supply into the power supply connector. Both Hub LED's will illuminate. Insert both power jumpers and ground jumper only on only the circuits that utilize a powered accessory (e.g. MatchJack, mic preamp, etc.).

Grounding Information

RJ-45 connector shields may be isolated from each other or optionally connected to each other or to the hub chassis by inserting jumper by each connector.

To use the hub as a common ground point, insert a jumper above any left-hand RJ-45 for any channel that you want to be in common with the chassis ground. If you have a StudioHub+ 15V power supply connected to the hub, to connect a channel to the power supply shield, insert a jumper above any right-hand RJ-45 of that channel.

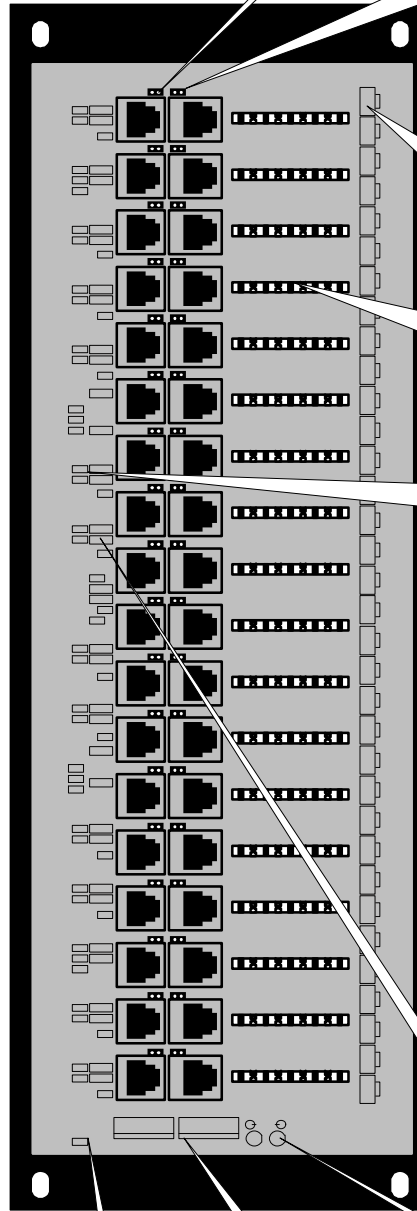
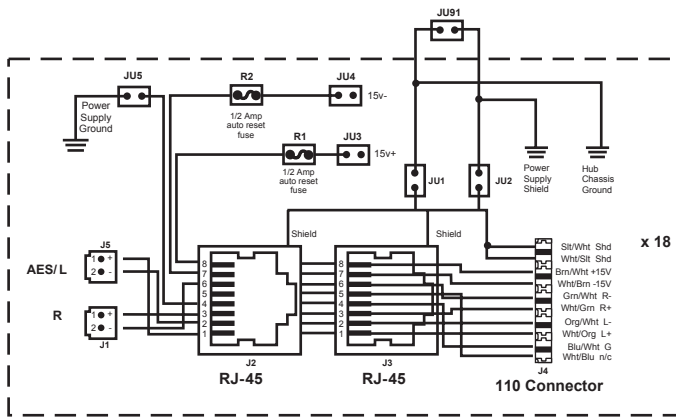

Insert a jumper above any left-hand RJ-45 to connect that channel to the common Hub chassis ground boss

Insert a jumper above any right-hand RJ-45 to connect that channel to the power supply shield

Upper and lower 2-pin mini-amp connectors wire to source gear audio I/O via certain harness cables

10 pin 110-style connector provides access to all 4 CAT-5 pairs and cable shield

Install both DC jumpers to activate StudioHub+ "DC-Link" connection to provide +/-15V DC to any powered accessory

Note: All 3 of these jumpers must be inserted for any channel that is powering a remote "DC-Link" device (e.g. StudioHub+ MatchJack or Pre-Amp)

This jumper connects the channel to the common power ground bus when installed. Required for "DC-Link" operation.

Note: This jumper must be removed for KVM extender links and other data devices that use CAT-5 wire #4 (blu/wht)

+/-15V external power supply main and loop-thru jumpers

LED's indicate presence of +/- 15V DC

Insert jumper JU91 to connect the chassis ground to the power supply shield

For Assy:
HUB32
Rev: 01/05

StudioHub+ Model HUB32

Engineered for Console Harnesses

Product Key	
Name	HUB32
Mount	Rack (1 R.U.)
Channels	32
CAT-5 Pairs	2 (1,2,3,6)
Power Link	no
Connectors	Mini-amp & RJ-45
Versions	Rack Mount

General

Each of the 32 Hub channels consists of two 2-pin mini-Amp input connectors in parallel with an RJ-45. Each channel carries a stereo balanced audio pair, or balanced digital audio signal. Custom length and configuration harness cables may be factory ordered to interconnect the Hub to various consoles, audio routers and engines or multi-channel Digital Audio Workstations.

There are two rear panel mini-Amp connectors which provide connectivity to pairs 1 & 2 of each front-panel RJ-45. Harness cables may be plugged up to program each channel for analog stereo, mono or AES-EBU operation.

Grounding Information

RJ-45 connector shields are isolated from each other and from the front panel metalwork.

A rear panel ground pin exists to allow the interconnection of a ground lead from the harness cable bundle.

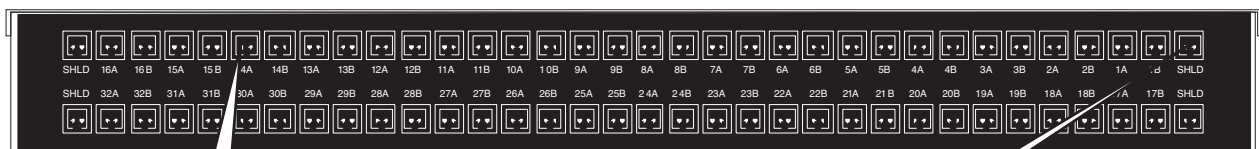
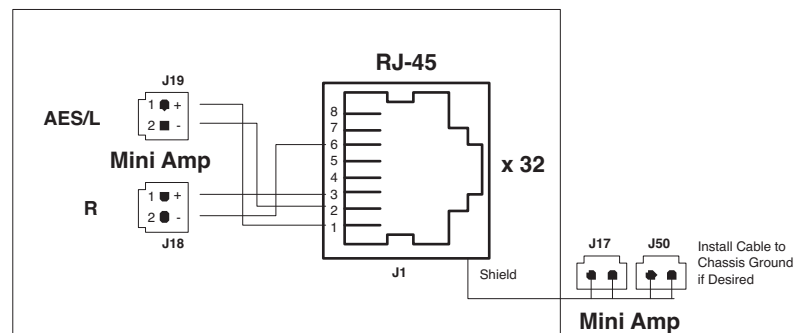

Pair 1 & 2 mini-amp 2-pin connectors for each channel. Plug in 2 cables for analog stereo, 1 cable for analog mono, or AES/EBU digital

Ground connect to chassis ground

Rear Panel (internal)

For Assy:
HUB36-DC
Rev: 01/05

StudioHub+ Model HUB36-DC

Engineered for Console Harnesses

Product Key	
Name	HUB36
Mount	Hub (3 R.U)
Channels	36
CAT-5 Pairs	2 (pins - 1,2,3&6)
Power Link	yes
Connectors	Mini-amp & RJ-45
Versions	Full Hub

General

Each of the 36 Hub channels consists of two 2-pin mini-Amp input connector in parallel with an RJ-45 connector. Each channel carries a stereo balanced audio pair, or balanced digital audio signal. Custom length and configuration harness cables may be factory ordered to interconnect the Hub to various consoles, audio routers and engines or multi-channel Digital Audio Workstations.

DC Power

If using any StudioHub+ "DLink" accessories, plug a StudioHub +/- 15 volt power supply into the power supply connector. Both Hub LEDs will illuminate. Insert both power jumpers only on only the circuits that utilize a powered accessory (e.g. MatchJack, mic preamp, etc.).

Grounding Information

RJ-45 connector shields may be isolated from each other or optionally connected to each other or to the hub chassis by inserting jumper by each connector.

To use the hub as a common ground point, insert a jumper below each RJ-45 that you want common to be in common with the chassis ground. If you have a StudioHub+ 15V power supply connected to the hub, to connect each RJ-45 to the power supply shield, insert a jumper above each RJ-45. Insert JU-33 to common the chassis ground and power-supply shield.

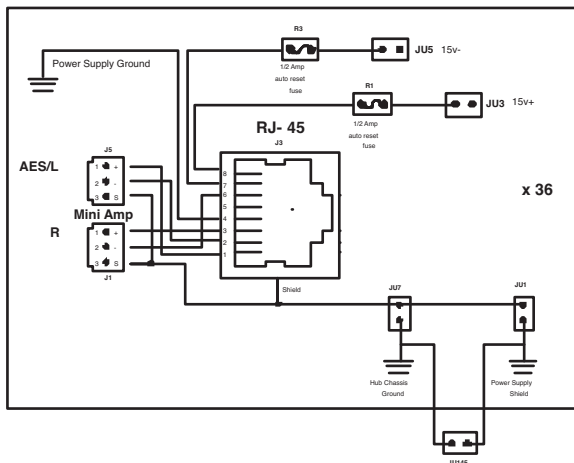
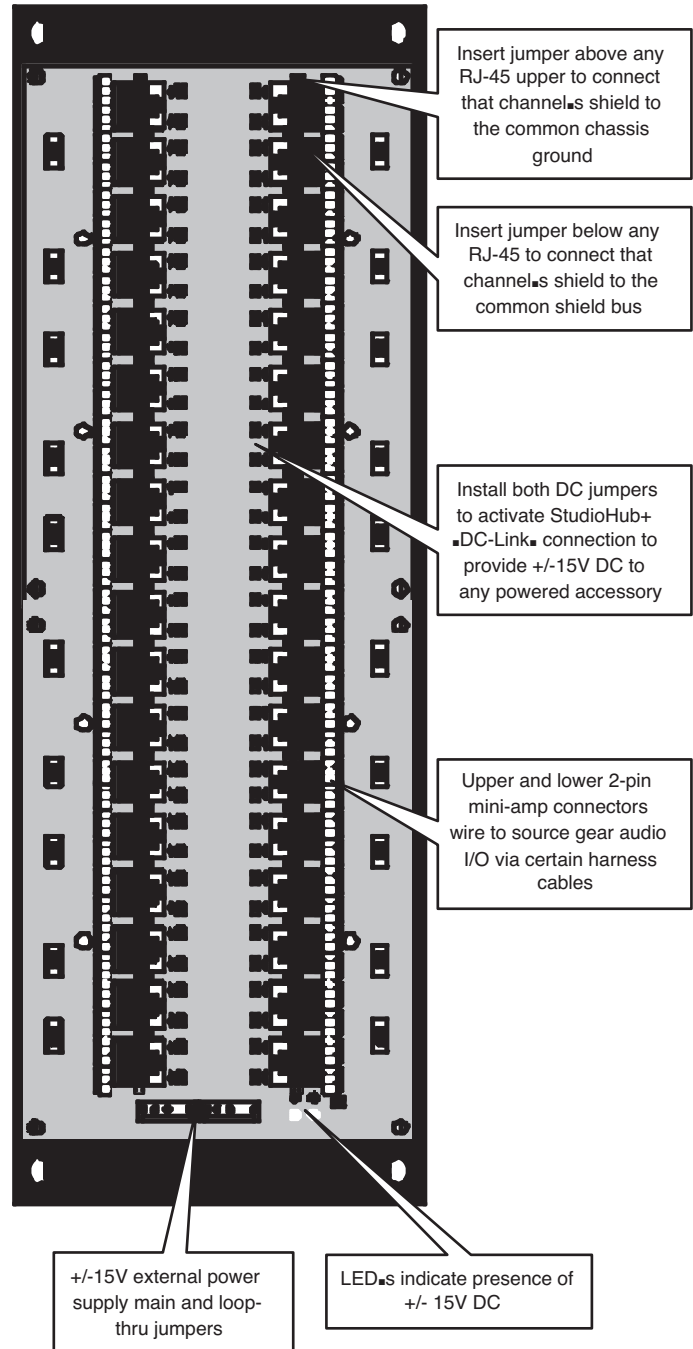

For Assys:
HUB12
Rev: 01/05



StudioHub+ Model HUB12

Engineered for StudioHub+ to Audio Science Audio Card Break-Out

Product Key	
Name	HUB12
Mount	rack (1 r.u.)
Channels	8 Out / 4 In
CAT-5 Pairs	2 (all)
Power Link	no
Connectors	12 RJ-45 / 2 BNC (for sync.) 1 MD-50 (for analog) / 1 MD-26 (for digital)
Versions	Rack-mount only (as pictured)

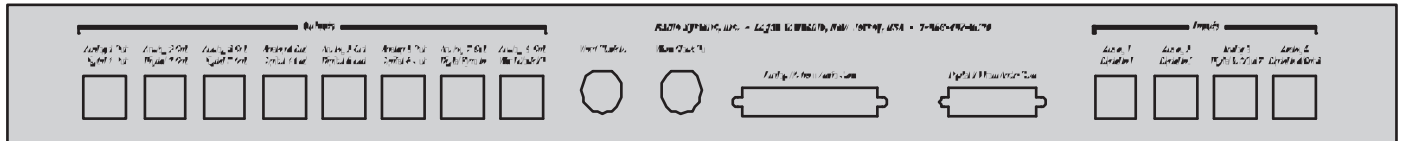

INPUT 1 LEFT -	1	26	INPUT 1 LEFT +	1	14	INPUT 1 AES +	1	14	INPUT 1 AES +	1	14
INPUT 1 RIGHT -	2	27	INPUT 1 RIGHT +	2	15	INPUT 2 AES -	2	15	INPUT 2 AES +	2	15
INPUT 2 LEFT -	3	28	INPUT 2 LEFT +	3	16	INPUT 3 AES -	3	16	INPUT 3 AES +	3	16
INPUT 2 RIGHT -	4	29	INPUT 2 RIGHT +	4	17	INPUT 4 AES -	4	17	INPUT 4 AES +	4	17
INPUT 3 LEFT -	5	30	INPUT 3 LEFT +	5	18	OUTPUT 1 AES -	5	18	OUTPUT 1 AES +	5	18
INPUT 3 RIGHT -	6	31	INPUT 3 RIGHT +	6	19	OUTPUT 2 AES -	6	19	OUTPUT 2 AES +	6	19
INPUT 4 LEFT -	7	32	INPUT 4 LEFT +	7	20	OUTPUT 3 AES -	7	20	OUTPUT 3 AES +	7	20
INPUT 4 RIGHT -	8	33	INPUT 4 RIGHT +	8	21	OUTPUT 4 AES -	8	21	OUTPUT 4 AES +	8	21
OUTPUT 4 RIGHT -	9	34	OUTPUT 4 RIGHT +	9	22	OUTPUT 5 AES -	9	22	OUTPUT 5 AES +	9	22
OUTPUT 4 LEFT -	10	35	OUTPUT 4 LEFT +	10	23	OUTPUT 6 AES -	10	23	OUTPUT 6 AES +	10	23
OUTPUT 3 RIGHT -	11	36	OUTPUT 3 RIGHT +	11	24	Sync	11	24	Word Clock	12	25
OUTPUT 3 LEFT -	12	37	OUTPUT 3 LEFT +	12	25	GROUND	13	26	GROUND	13	26
OUTPUT 2 RIGHT -	13	38	OUTPUT 2 RIGHT +	13	26						
OUTPUT 2 LEFT -	14	39	OUTPUT 2 LEFT +	14	27						
OUTPUT 1 RIGHT -	15	40	OUTPUT 1 RIGHT +	15	28						
OUTPUT 1 LEFT -	16	41	OUTPUT 1 LEFT +	16	29						
OUTPUT 5 RIGHT -	17	42	OUTPUT 5 RIGHT +	17	30						
OUTPUT 5 LEFT -	18	43	OUTPUT 5 LEFT +	18	31						
OUTPUT 6 RIGHT -	19	44	OUTPUT 6 RIGHT +	19	32						
OUTPUT 6 LEFT -	20	45	OUTPUT 6 LEFT +	20	33						
OUTPUT 7 RIGHT -	21	46	OUTPUT 7 RIGHT +	21	34						
OUTPUT 7 LEFT -	22	47	OUTPUT 7 LEFT +	22	35						
OUTPUT 8 RIGHT -	23	48	OUTPUT 8 RIGHT +	23	36						
OUTPUT 8 LEFT -	24	49	OUTPUT 8 LEFT +	24	37						
GROUND	25	50	GROUND	25	38						

Analog I/O Connector (MD-50)

NOTE - These pin-outs typically correlate 1 to 1 for Audio Science series 4000, 5000 and 6000 audio cards so that straight-thru patch cables may be utilized.

Digital I/O Connector (MD-26)

General

The Hub12 is specifically engineered to break-out up to 8 stereo output channels and 4 stereo input channels from series 4000, 5000 and 6000 Audio Science professional multi-channel audio cards. Inputs and outputs appear on RJ-45 connectors and conform to the StudioHub+ audio pin-out standard. Front panel high-density MD-50 & MD-26 connectors mate with similar connectors on the various ASI cards supported.,

BNC Synchronous connectors

Front panel BNC connectors provide Word-Clock sync inputs and outputs as supported by the individual ASI card models. Insert internal jumpers JU-9 & JU-10 to activate these connectors.

Grounding Information

Front panel RJ-45 shields are all normally isolated from each other, but may be connected together via a common ground bus by inserting internal jumpers JU-1 thru JU-12. This bus may be connected to the HUB12 chassis ground by inserting internal jumper JU-15.

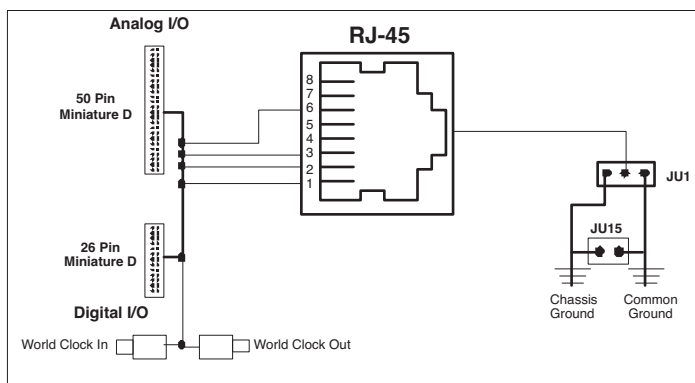

StudioHub+ Pin Outs

Channel	Color Pair	RJ-45 Pin	110 Pin
L+ / AES +	Wht/Org	1	3
L- / AES -	Org/Wht	2	4
R+	Wht/Grn	3	5
R-	Grn/Wht	6	6
nc	Wht/Blu	5	1
GND	Blu/Wht	4	2
15V-	Wht/Brn	7	7
15V+	Brn/Wht	8	8
Shield	Wht/Slit	Shield	9
Shield	Slit/Wht	Shield	10

For Assy:
HUB24
Rev: 01/05

StudioHub+ Model HUB24

Product Key	
Name	HUB24
Mount	Rack (1 R.U.)
Channels	24
CAT-5 Pairs	4 (all)
Power Link	no
Connectors	2 RJ-45
Versions	Rack-Mount

General

Each of the 24 Hub channels consists of two 2 RJ-45 connectors in parallel. Each channel carries all 8 CAT-5 conductors and is capable of supporting all types of StudioHub+ and CAT-5 connectivity.

Typical HUB24 applications are as a tie-point where a connection of all 4 CAT-5 pairs is required, or to gain access to CAT-5 cables for patching or routing purposes.

Grounding Information

RJ-45 connector shields are connected from the top to bottom connector, but are isolated from other RJ-45 channels and from the front panel metalwork.

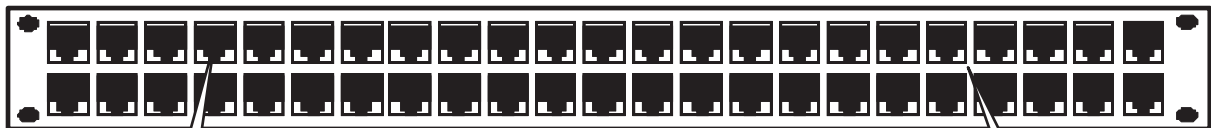
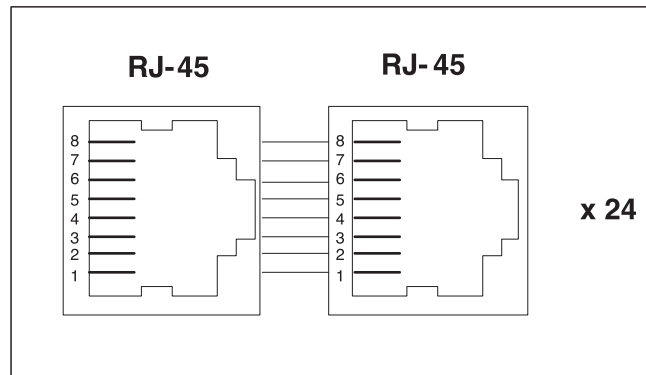

Each upper RJ-45 is in parallel with the RJ-45 below it

All 8 conductors pass between the connectors

For Assy:
HUBRIO
Rev: 12/12

StudioHub+ Model HUB RJ21 SAS RIO

Engineered for SAS RIO Studio I/O Chassis

Product Key	
Name	HUB RJ21 SAS Rio
Mount	Hub (3 R.U.)
Channels	32/64
CAT-5 Pairs	2
Power Link	no
Connectors	4 RJ-21 & 64 RJ-45
Versions	Full Hub

General

The HUB RJ21 SAS RIO is designed for use exclusively with the SAS RIO Studio I/O Chassis.

Via 4 CAT-5 25-pair RJ21 cables (supplied separately), the hub provides breakout for up to 4 RIO analog or digital, input or output cards.

On-Hub programming jumpers, allow the assignment of 2 analog signals to 1 stereo RJ-45 connector, or AES-EBU or mono analog signals to individual RJ-45 connectors.

Grounding Information

RJ-45 connector shields may be optionally connected to the chassis ground by inserting a jumper. A jumper is also provided to allow the unused CAT-5 25th pair to be connected to this common shield bus.

Jumper Programming

Configuration #1 - Analog Stereo

Connect only to inner RJ-45 (left channel on pins 1&2, right channel on pins 3&6 of inner RJ-45 only).

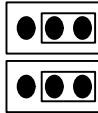

Short center and pin nearest inner RJ-45 on both jumpers

Configuration #2 - Analog Mono or AES / EBU

Left Mono or AES/EBU to inner RJ-45 and Right Audio or AES/EBU to outer RJ-45 (channel #1 to pins 1&2 of inner RJ-45, channel #2 to pins 1&2 of outer RJ-45).

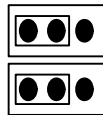

Short center and pin nearest outer RJ-45 on both jumpers

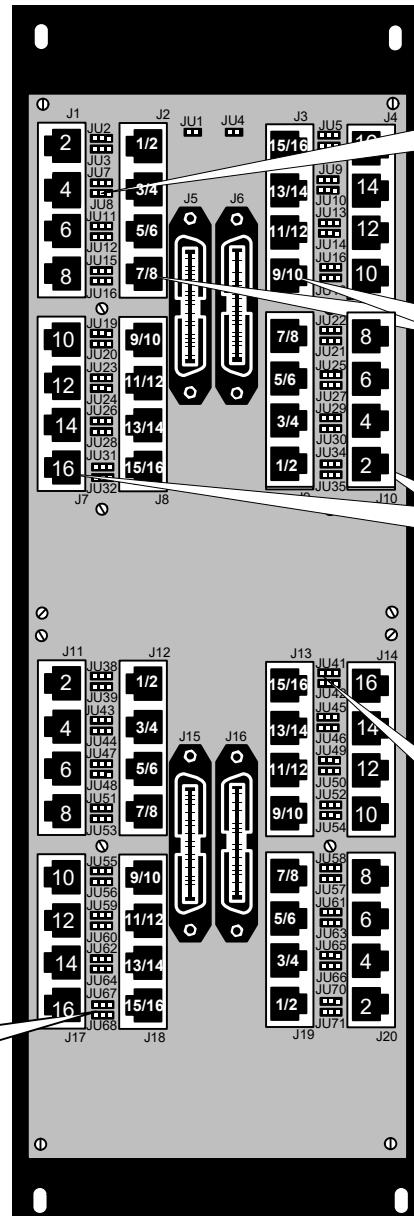

For EAS/EBU program and use top 8 (inner and outer) RJ-45's only.

Inner RJ-45's provide analog stereo or left channel or AES-EBU connectivity

Outer RJ-45's provide analog right channel or AES-EBU connectivity

Set jumpers for RJ-45 stereo or mono or AES-EBU connections

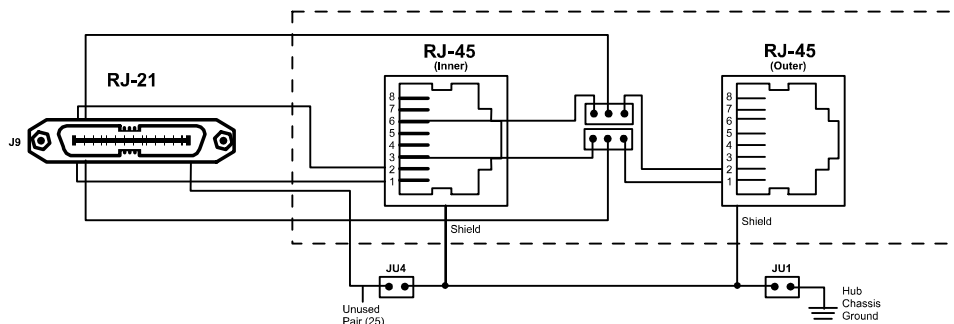

StudioHub+ GPI 12/24 Channel Remote Control Hub

General

The GPI Hub-12/24 allows the use of pre-programmed RJ-45 to DB connector adapters, for plug and play remote control of many broadcast units.

DB to RJ-21 cables are provided to interconnect most popular GPI controllers to the Hub-12/24, where the user than crosscut the 110 connectors to program various remote control functionality.

Two models are available. Order the GPI Hub-12 for 12 channels of control, or the dual GPI Hub-24 for 24 channels of control.

DC Power & Grounding

A barrier strip connector is provided for DC power. Programming jumpers for each RJ-45 channel allow quick programming of ground and DC when required on the RJ-45 connection to the controlled unit.

Order model GPI Hub-12 for a single circuit board unit with 1 RJ-21 and 12 RJ-45 connectors.

Order model GPI Hub-24 for a dual circuit board unit which adds the lower circuit board for 2 RJ-21 and 24 RJ-45 connectors.

RJ-21 Interconnect Cables

Custom RJ-21 to DB connector cables are available to interconnect every major GPI controller to the GPI Hub

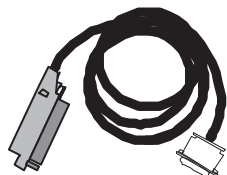

RJ-45 Control Adapters

Custom RJ-45 to DB connector adapters are available pre-programmed to connect every major manufacturers DB remote control connector to the GPI hub via standard RJ-45 patch cables

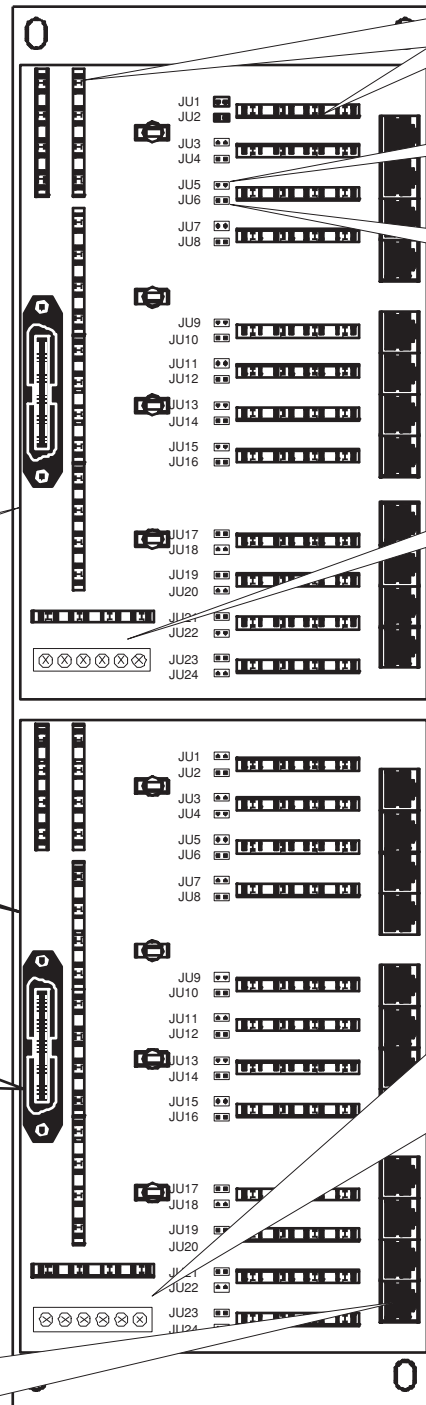
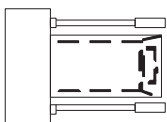

Cross-cut between RJ-21 110 connectors and RJ-45 110 connectors to program RJ-21 to RJ-45 control line connectivity

Install this jumper at any channel to connect ground to Pin #5 of the RJ-45

Install this jumper at any channel to connect DC + voltage to Pin #8 of the RJ-45

Connect DC voltage and/or ground at this 110 block or screw terminal to apply ground or DC voltage to these RJ-45 jumpers. (See below for specific programming instructions).

Power & Ground Programming

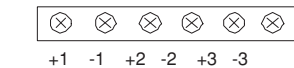

Note: These connectors are in parallel

3 groups of + and ground connections are available. Each group feeds 3 sets of 4 RJ-45 connectors.

To send DC to pin 8 of the RJ-45's in group 1 (RJ-45's 1-4), apply DC to screw terminal +1 or 110 connector pin +1. Then install jumper JU2, JU4, JU5, JU6, or JU8 at each RJ-45 where DC needs to be present.

To send ground to pin 5 of the RJ-45's in group 1 (RJ-45's 1-4), apply ground to screw terminal -1 or 110 connector pin -1. Then, install jumper JU1, JU3, JU5, or JU7 at each RJ-45 where ground needs to be present.

Repeat (with appropriate screw terminal and jumper numbers) for RJ-45 group 2 (RJ-45's 5-8) and group 3 (RJ-45 9-12)

Note that if the same DC voltage or ground connection is needed between groups, the DC or ground lead can be connected in parallel at the lower screw terminals or the 110 connector.

For Assys:
GPI16
Rev: 07/05

StudioHub+ GPI 16 Channel Remote Control Hub

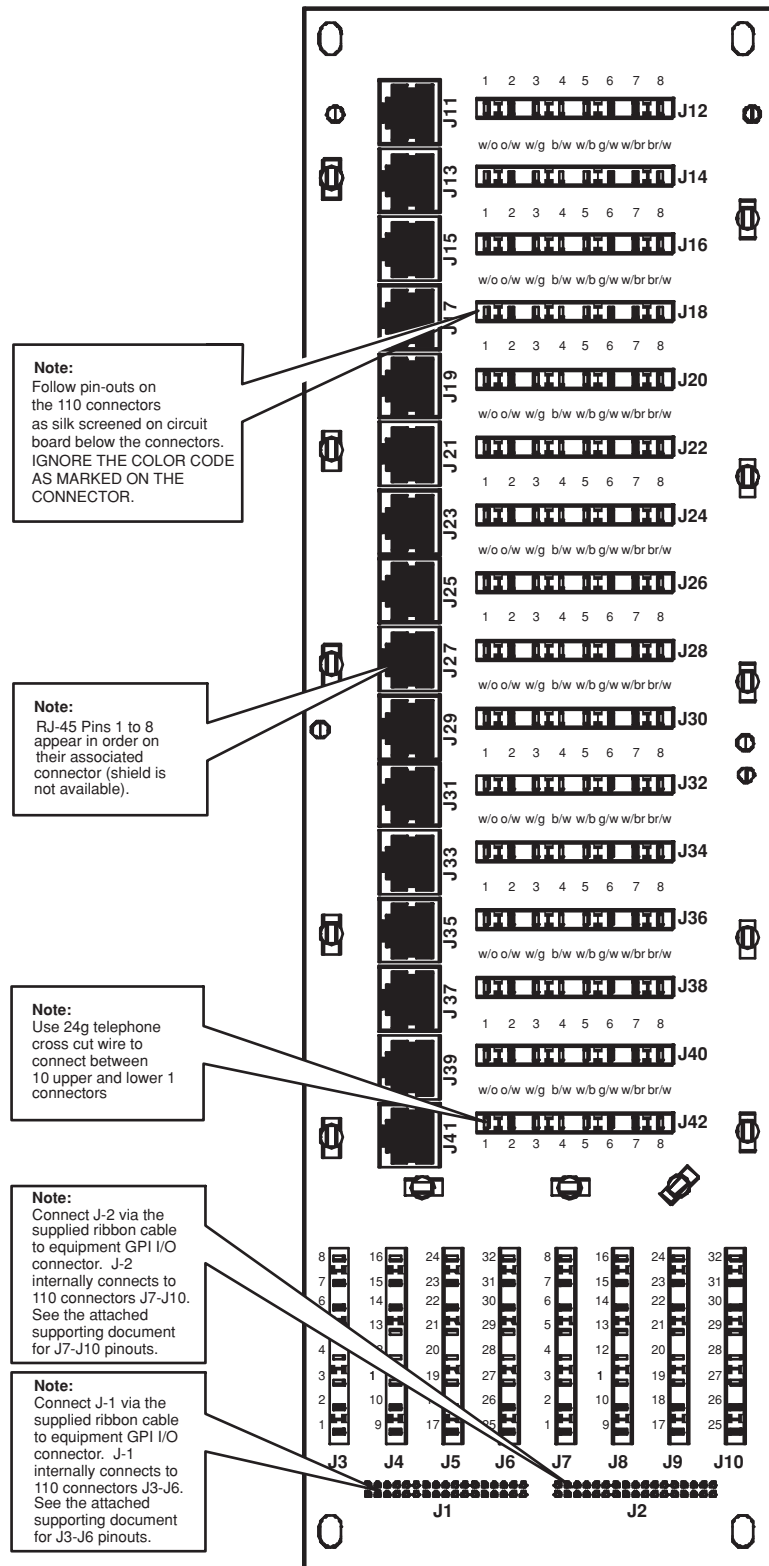

For Assy:
 MINITIE12-4
 MINITIE24-4
 Rev: 01/05

StudioHub+ Model MINITIE12-4 & MINITIE24-4

Engineered for Inter-Studio Tie Lines

General

Mini Tie Hubs provide multi-pair inter-studio connectivity by splaying out CAT-5 25 pair cable to individual RJ-45 connectors via a 50 pin RJ-21 mass connector. Mini Hubs are designed to mount and fit where the capacity of full-size hubs is not needed. Depending on the model selected, either 2 or 4 CAT-5 pairs are connected to each RJ-45 connector. Double the density is achieved if only 2 pairs (4 wires) are required to connect to each RJ-45. Generally, 2 pair is sufficient to support StudioHub analog and digital audio circuits. All 4 pairs (8 wires) are needed to support KVM and other special multi-wire equipment circuits.

Mounting

Mini tie-line hubs are available in single units on small wall-mountable plates, or in double density on 1 r.u. rack mounts

Grounding Information.

RJ-45 connector shields are common on the mini tie hubs.

Two jumpers are provided that allow the unused CAT-5 25th pair to be connected to this common shield, as well as to the hub chassis.

Product Key

Name	MINITIE12-4 / MINITIE24-4
Mount	Wall Mount / Rack Mount (1 r.u.)
Channels	24 / 12
CAT-5 Pairs	2 (pins - 1,2,3,6)
Power Link	no
Connectors	RJ-21, RJ-45
Versions	Plate, Rack

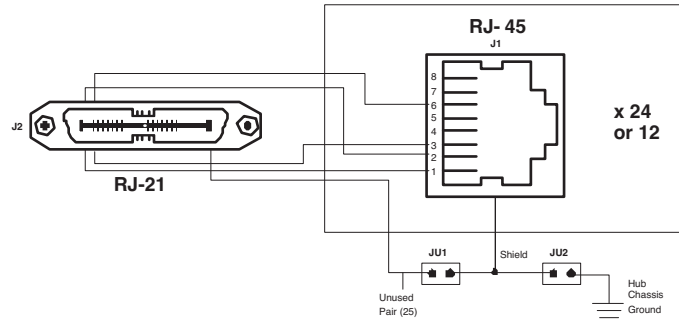

Each RJ-45 provides 4 wires of connectivity via the CAT-5 25-pair cable

Model - MINITIE12-4

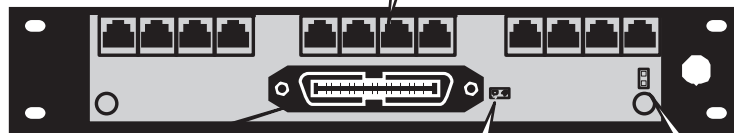

RJ-21 connects 25-pair CAT-5 cable carrying six 4-pair circuits. One 25-pair CAT-5 cable is required for 12 circuit model. Two 25-pair CAT-5 cables are required for 24 circuit model.

Insert jumper to tie power supply shield to hub chassis ground

Insert jumper to tie power supply shield to hub chassis ground

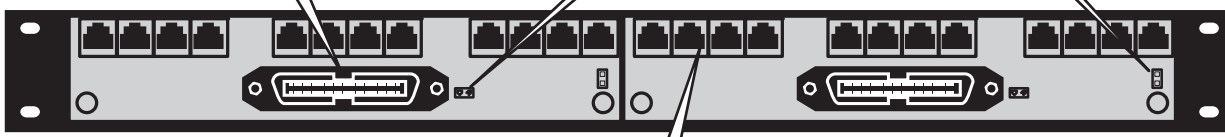

Model - MINITIE24-4

Each RJ-45 provides 4 wires of connectivity via the CAT-5 25-pair cable

For Assy:
 MINITIE12-8
 MINITIE6-8
 Rev: 01/05

StudioHub+ Model MINITIE6-8 & MINITIE12-8

Engineered for Inter-Studio Tie Lines

General

Mini Tie Hubs provide multi-pair inter-studio connectivity by splaying out CAT-5 25 pair cable to individual RJ-45 connectors via a 50 pin RJ-21 mass connector. Mini Hubs are designed to mount and fit where the capacity of full-size hubs is not needed. Depending on the model selected, either 2 or 4 CAT-5 pairs are connected to each RJ-45 connector. Double the density is achieved if only 2 pairs (4 wires) are required to connect to each RJ-45. Generally, 2 pair is sufficient to support StudioHub analog and digital audio circuits. All 4 pairs (8 wires) are needed to support KVM and other special multi-wire equipment circuits.

Mounting

Mini tie-line hubs are available in single units on small wall-mountable plates, or in double density on 1 r.u. rack mounts

Grounding Information.

RJ-45 connector shields are common on the mini tie hubs.

Two jumpers are provided that allow the unused CAT-5 25th pair to be connected to this common shield, as well as to the hub chassis.

Product Key	
Name	MINITIE6-8 / MINITIE12-8
Mount	Wall Mount / Rack Mount (1 r.u.)
Channels	6/12
CAT-5 Pairs	8 (all)
Power Link	no
Connectors	RJ-21, RJ-45
Versions	Plate, Rack

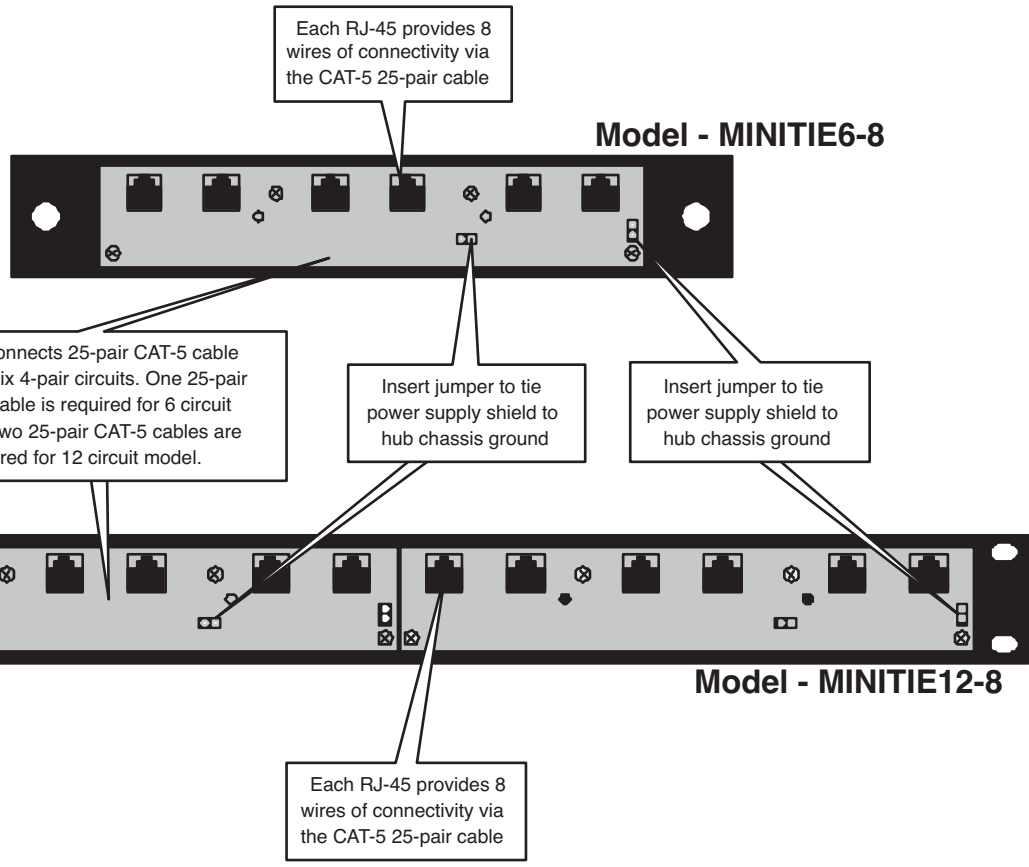
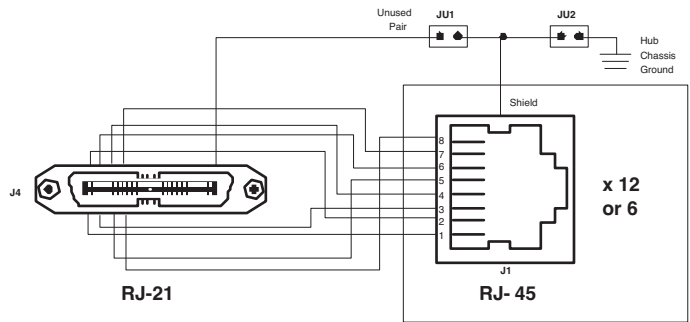

For Assy:
TIE24-4DC
TIE12-4DC
Rev: 01/05

StudioHub+ Model Tie-24-4DC & Model Tie-12-4DC

Engineered for Inter-Studio Tie Lines

Model TIE24-4DC shown
also available as Ω hub 12 channel - model TIE12-4DC

Product Key	
Name	TIE24-4Powered
Mount	Full Hub/Half Hub
Channels	24/12
CAT-5 Pairs	2 (pins - 1,2,3,6)
Power Link	yes
Connectors	RJ-21/ 2 RJ-45
Versions	Full Hub/Half Hub/Board Only

General

Tie Hubs provide multi-pair inter-studio connectivity by splicing out CAT-5 25 pair cable to individual RJ-45 connectors via a 50 pin RJ-21 mass connector. Depending on the model selected, either 2 or 4 CAT-5 pairs are connected to each RJ-45 connector. Double the density is achieved if only 2 pairs (4 wires) are required to connect to each RJ-45. Generally, 2 pair is sufficient to support StudioHub analog and digital audio circuits. All 4 pairs (8 wires) are needed to support KVM and other special multi-wire equipment circuits.

DC Power

■DC■ Tie-Line hub models allow StudioHub+ ■DC-Link■ +/- 15 volt power to be added on the far-side of the link to power local StudioHub+ powered peripherals (such as headphone amps and MatchJacks). An external StudioHub+ DC power supply must be utilized. Jumpers and re-settable fuses for each RJ-45 channel allow the DC power to be added. The power option is only available on 2-pair per RJ-45 Hub models.

Grounding Information

RJ-45 connector shields may be optionally connected to the chassis ground by inserting a jumper. A jumper is also provided to allow the unused CAT-5 25th pair to be connected to this common shield bus. In addition, on powered models, the power supply shield may be jumper connected to the RJ-45 shields.

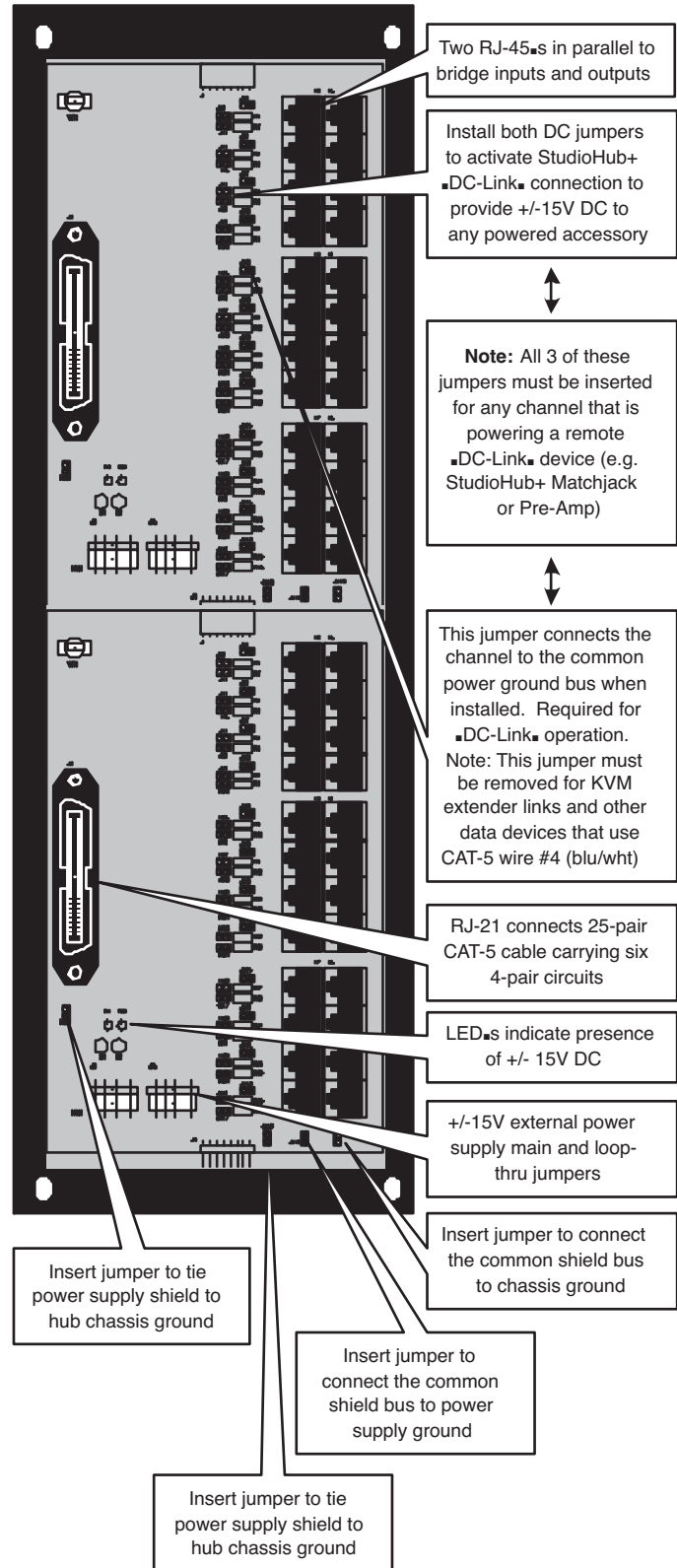
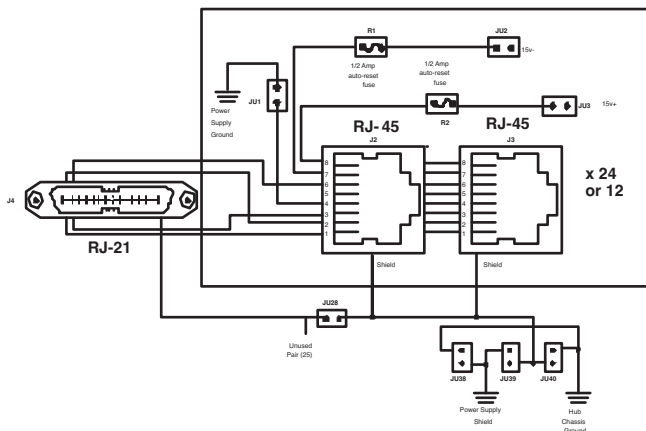

For Assy:
TIE24-8,
TIE12-8
Rev: 01/05

StudioHub+ Model TIE24-8 & Model TIE12-8

Engineered for Inter-Studio Tie Lines

Model TIE24-8 pictured
also available as Ω hub 12 channel - model TIE12-8

Product Key	
Name	TIE24-8 / TIE12-8
Mount	Full Hub / Half Hub
Channels	12 / 12
CAT-5 Pairs	4 (all)
Power Link	no
Connectors	RJ-21, 2 RJ-45 & 110
Versions	Full Hub/Half Hub/Board Only

General

Tie Hubs provide multi-pair inter-studio connectivity by splaying out CAT-5 25 pair cable to individual RJ-45 connectors via a 50 pin RJ-21 mass connector. Depending on the model selected, either 2 or 4 CAT-5 pairs are connected to each RJ-45 connector. Double the density is achieved if only 2 pairs (4 wires) are required to connect to each RJ-45. Generally, 2 pair is sufficient to support StudioHub analog and digital audio circuits. All 4 pairs (8 wires) are needed to support KVM and other special multi-wire equipment circuits.

DC Power

■DC■ Tie-Line hub models allow StudioHub+ ■DC-Link■ +/- 15 volt power to be added on the far-side of the link to power local StudioHub powered peripherals (such as headphone amps and MatchJacks). An external StudioHub+ DC power supply must be utilized. Jumpers and re-settable fuses for each RJ-45 channel allow the DC power to be added. The power option is only available on 2-pair per RJ-45 Hub models.

Grounding Information

RJ-45 connector shields may be optionally connected to the chassis ground by inserting a jumper. A jumper is also provided to allow the unused CAT-5 25th pair to be connected to this common shield bus. In addition, on powered models, the power supply shield may be jumper connected to the RJ-45 shields.

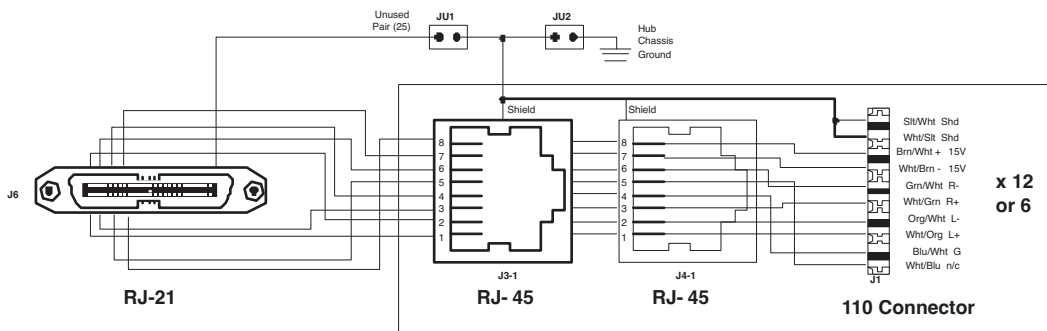
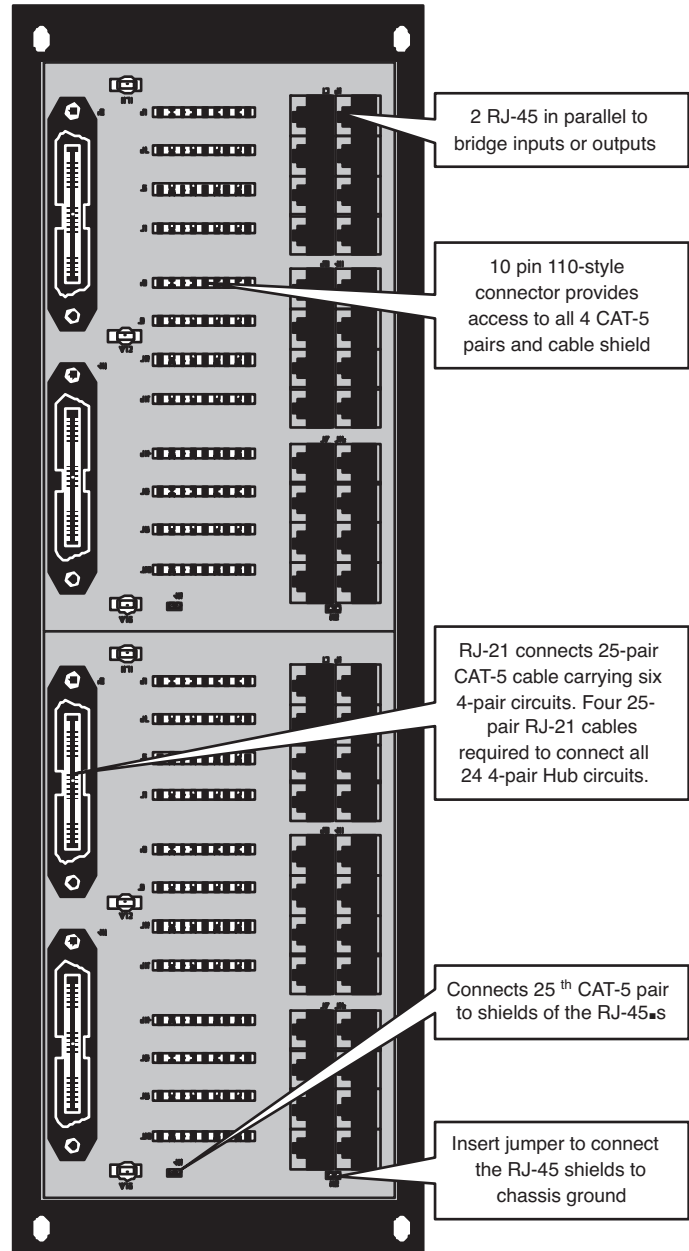

For Assy:
 PATCH-44
 Rev: 01/05

StudioHub+ Model PATCH-44

with Front Panel Normalizing Switching

General

The StudioHub+ 44 position patch panel provides 22 stereo analog or digital outputs and inputs on a 3 r.u. rack panel via RJ-45 connectors. Standard RJ-45 shielded or non-shielded ■straight-thru■ patch cords of 18■ or longer may be used to make patch connections.

Normalling

Front panel accessible ■normalling■ dip-switches establish a ■quarter normalled■ full-time connection between the upper and lower output and input connectors so that signal in made without the use of a patch-cord. Note that when the normalling function switch is on (up,) signal flow is not interrupted by inserting a RJ-45 patch cord in either the upper or lower circuit connector.

Rear Panel Connectivity

44 Rear panel RJ-45■s are provided in parallel with the front panel connectors for plug-and-play wiring ease to the panel. In addition, rear panel 110-style punch blocks are in-line for every circuit to allow cabling access to every signal. Note that the panel passes 2 pairs (pins 1, 2, 3, &6) of the CAT-5 cable, leaving pairs 3&4 unconnected. This makes the panel compatible for StudioHub+ analog and digital audio connectivity as well as certain Ethernet applications, but not CAT-5 circuits requiring other then pairs 1 & 2.

Grounding Information.

RJ-45 connector shields are isolated from each other but may be optionally connected in common by inserting a jumper on the rear of the panel by each connector. A jumper is also provided to connect the RJ-45 shield bus to the patch panel chassis ground.

Rear-Panel Connectivity on RJ-45 and 110 punch-blocks

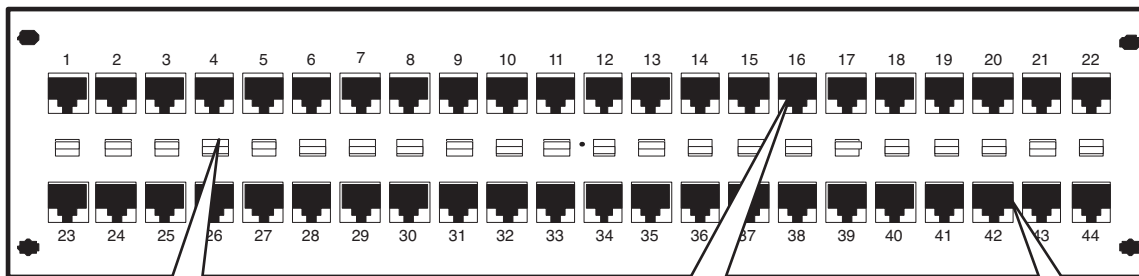
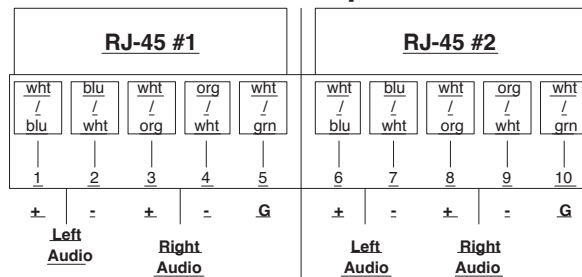

Front Panel normalizing switch connects upper jack left & right audio inputs to lower jack left & right audio outputs when switch is in up position. Audio remains present (monitorable) on both input & output jacks regardless of normalizing switch position or the insertion of patch cords.

Each RJ-45 jack provides a stereo balanced audio circuit. Jacks are shielded, with a ground connection that may be floated or commoned via a rear panel jumper to chassis ground.

Audio connection to each front panel jack is provided on the rear panel via a parallel RJ-45 connector or 110 punch style connection (see chart below)

For Assy:
PATCH48
Rev: 04/09

StudioHub+ Model PATCH - 48 - 2 Rack Units High with Interchangeable Rear Adapters



24 Channels of RJ-45 Thru-Put with Front Panel Normalizing Switching
and Rear-Panel Interchangeable Connector Adapters (See Rear for Adapter Pin-Outs)

Front Panel normalizing switch connects upper jack left & right audio inputs to lower jack left & right audio outputs when switch is in up position. Audio remains present (monitorable) on both input & output jacks regardless of normalizing switch position or the insertion of patch cords.

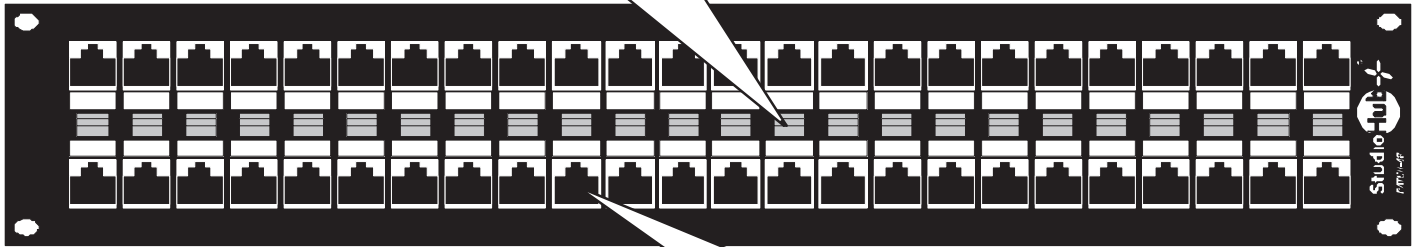

Each RJ-45 jack provides a stereo balanced audio or AES/EBU digital circuit. Jacks are shielded, with a ground connection that may be floated or commoned via a rear panel jumper to chassis ground.

Available Rear Adapters

Install on top row and bottom row of rear panel (in any mix)

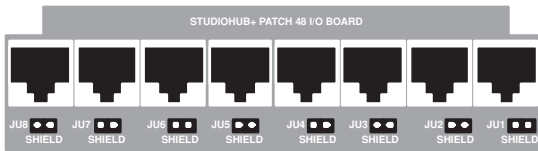

I/O MODEL (1/3 WIDTH REAR PANEL ADAPTER)

8 RJ-45 connectors each conducting 2-pair (RJ-45 pins 1,2,3 & 6) on a 1-to-1 basis from the front panel RJ-45's to the corresponding rear panel RJ-45.

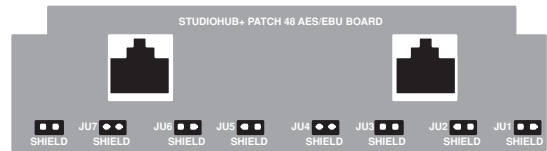

AES/EBU MODEL (1/3 WIDTH REAR PANEL ADAPTER)

2 RJ-45 connectors each conducting 4-pair (all RJ-45 pins) to 1-pair each (RJ-45 pins 1 & 2) of four front panel RJ-45's.

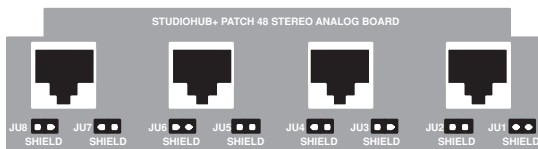

STEREO ANALOG MODEL (1/3 WIDTH REAR PANEL ADAPTER)

4 RJ-45 connectors each conducting 4-pair (all RJ-45 pins) to 2-pairs each (RJ-45 pins 1,2,3 & 6) of two front panel RJ-45's.

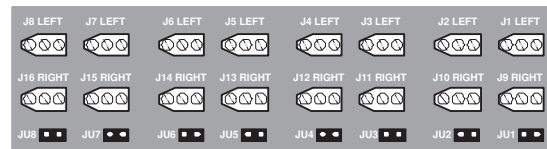

EDAC MODEL (1/3 WIDTH REAR PANEL ADAPTER)

16 EDAC #556003520102 male 3-pin connectors (with wings removed), each conducting 1 balanced audio signal to 1 channel of 1 front panel RJ-45.

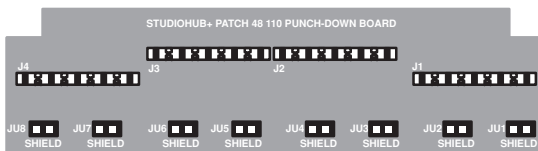

110 MODEL (1/3 WIDTH REAR PANEL ADAPTER)

4 dual 110 punch-down connectors each conducting two balanced circuits to one front panel RJ-45 connector (RJ-45 pins 1,2,3 & 6)

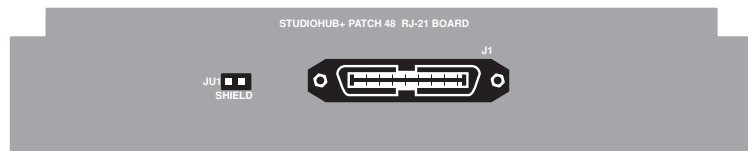

RJ-21 MODEL (1/2 WIDTH REAR PANEL ADAPTER)

One female RJ-21 connectors conducting twenty four to balanced circuits to twelve front panel RJ-45 connectors (RJ-45 pins 1,2,3 & 6)

NOTE: Adapters may be "mixed and matched" on the rear panel. Use up to 6 of the 1/3 width models and up to 4 of the 1/2 model adapters.

NOTE: All 2-pin jumpers connect RJ-45 connector shield to corresponding front panel RJ-45 shield. 2-pin jumper on RJ21 adapter connects 25th pair to RJ-45 to chassis ground.



Rear "Stereo Analog" Adapter Board

Four RJ-45 connectors with two stereo analog signals split to eight RJ-45 connectors with one stereo analog signal.

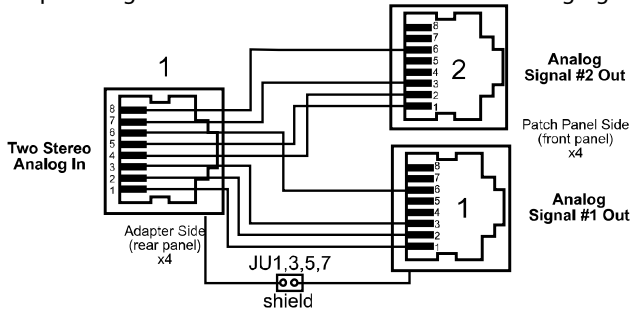

Rear "I/O" Adapter Board

Eight RJ-45 connectors with one AES/EBU signal or two balanced analog signals connected straight-thru to eight RJ-45 connectors.

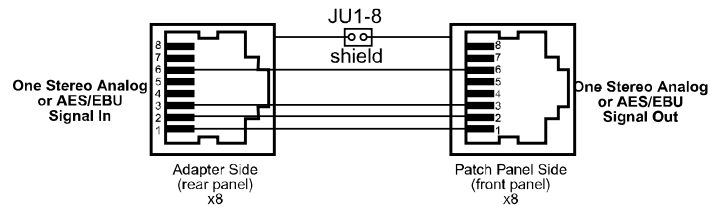

Rear "AES/EBU" Adapter Board

One RJ-45 connector with four AES/EBU signals split to four RJ-45 AES/EBU signals.

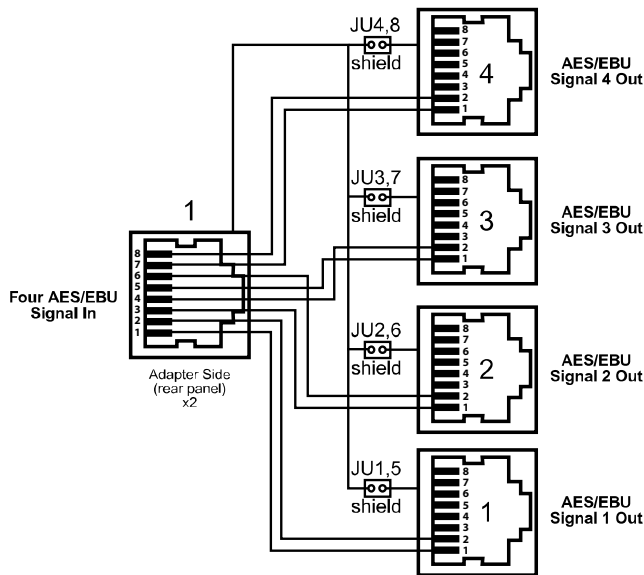

Rear "75 Ohm" Adapter Board

Eight BNC 75 Ohm, unbalanced digital inputs or outputs connected to eight AES 110 Ohm, balanced RJ-45 connectors.

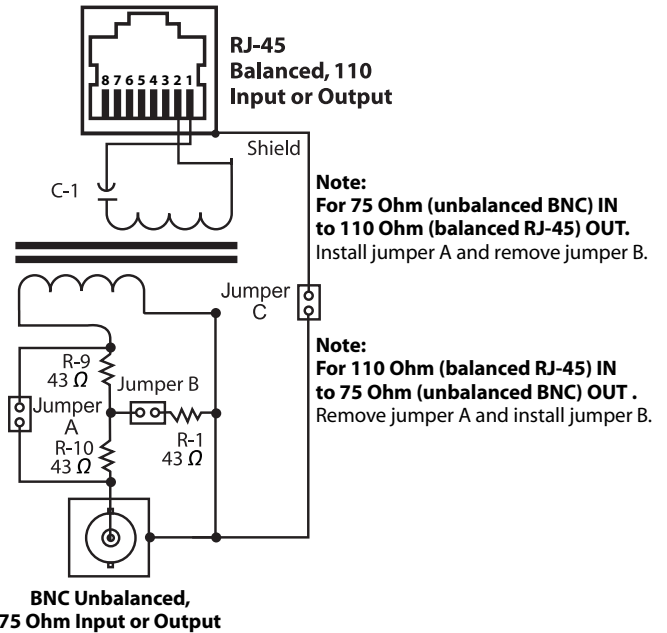

Rear RJ-21 Adapter Board

One RJ-21 connector with twelve stereo signals split to twelve RJ-45 connectors

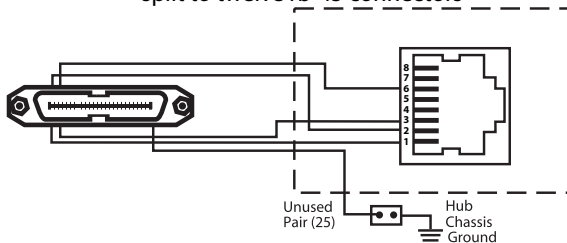

Pair	Color	RJ-21 Pins	RJ-45 #
1/2	wht,blu/wht,org	26,1/27,2	1
3/4	wht,grn/wht,brn	28,3/29,4	2
5/6	wht,slt/red,blu	30,5/31,6	3
7/8	red,org/red,grn	32,7/33,8	4
9/10	red,brn/red,slt	34,9/35,10	5
11/12	blk,blu/blk,org	36,11/37,12	6
13/14	blk,grn/blk,brn	38,13/39,14	7
15/16	blk,slt/yel,blu	40,15/41,16	8
17/18	yel,org/yel,grn	42,17/43,18	9
19/20	yel,brn/yel,slt	44,19/45,20	10
21/22	vio,blu/vio,org	46,21/47,22	11
23/24	vio,grn/vio,brn	48,23/49,24	12
25	vio,slt	50,25	Ground

Rear 110 Adapter Board

Two 10-Pin 110 connectors with four stereo signals split to four RJ-45 connectors

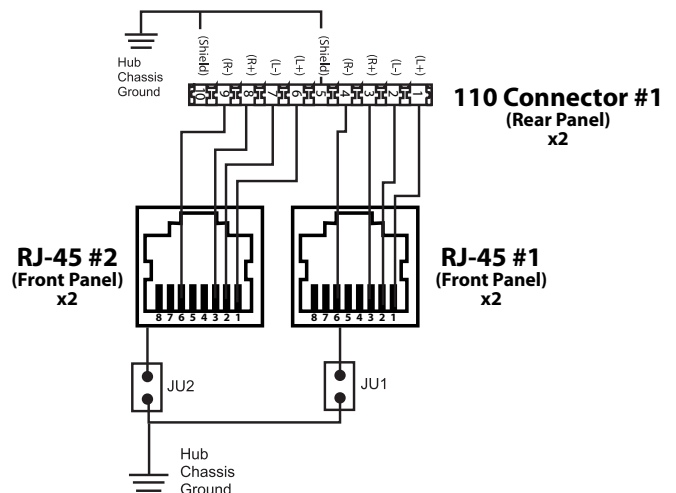

StudioHub+ Model SUM8 & Model SUM4 4x2 Stereo Audio Mixer Amplifier

For Assys:
Sum8
Sum4
Rev: 01/05

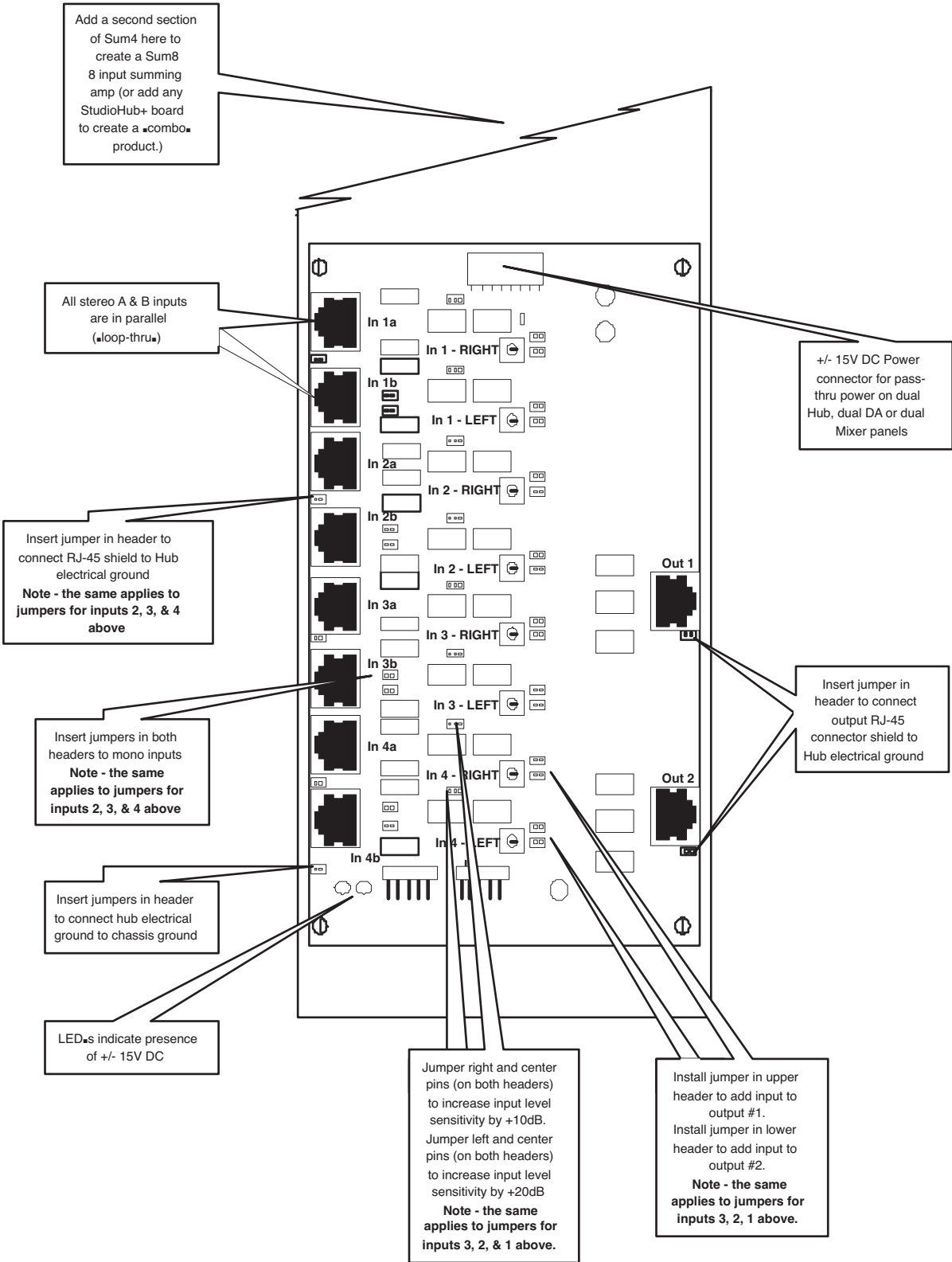

For Assys:
 DA12-DC
 DA6-DC
 Rev: 01/05

StudioHub+ Model DA12-DC & Model DA6-DC Single and Dual Stereo Distribution Amplifier

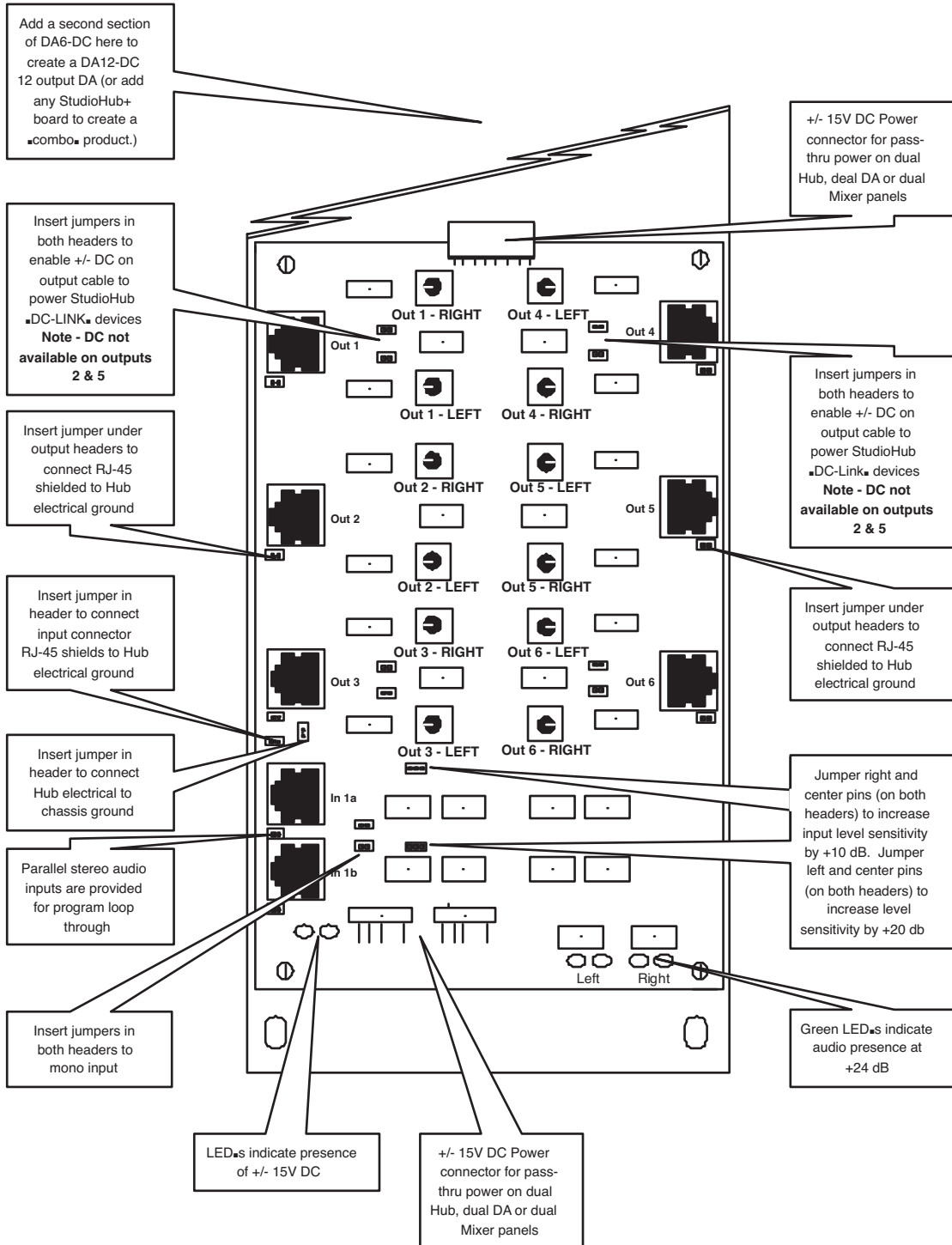



Angry Audio LLC

128 Holiday CT STE 118 • Franklin, TN 37067
+1 (615) 763-3033 • answers@angryaudio.com
www.angryaudio.com • www.studiohub.com